

## GFC 700 AUTOPILOT - MAINTENANCE PRACTICES (Airplanes with GSM 85 Servo Mounts)

### 1. General

- A. A three-axis autopilot with heading hold is installed as standard equipment on the airplane. The roll and yaw servos are the Garmin GFC 700 AFCS GSA 80 servos. The pitch and pitch trim are the Garmin GFC 700 AFCS GSA 81 servos. The servo mounts are the Garmin GFC 700 AFCS GSM 85 servo mounts.

### 2. Roll Servo Removal/Installation

- A. Remove the Roll Servo (Refer to Figure 201).
- (1) Disconnect electrical power from the airplane.
  - (2) Remove the copilot's seat. Refer to Chapter 25, Flight Compartment - Maintenance Practices.
  - (3) Remove the access panel 232DR. Refer to Chapter 6, Access Plates and Plates Identification - Description and Operation.
  - (4) Disconnect the electrical connector from the roll servo.
  - (5) Release the control cable tension and loosen the roll servo bridle cable at the turnbuckle.
  - (6) For airplanes 20800416, 20800514, 20800518 thru 20800523 and airplanes 208B2090 and 208B2168 thru 208B2230, remove the screws and the nuts that attach the roll servo fairlead cover to the fairlead guard assembly.
    - (a) Remove the roll servo fairlead cover from the fairlead guard assembly and the airplane.
  - (7) For airplanes 20800524 and On, 208B2231 and On, and airplanes that incorporate CAB10-9, remove the screws that attach the roll servo fairlead cover to the fairlead guard assembly.
  - (8) Remove the bolts and washers that attach the roll servo to the bracket assembly.
  - (9) Remove the roll servo from the airplane.
- B. Install the Roll Servo (Refer to Figure 201).
- (1) Put the roll servo actuator in position on the torque mount and attach with bolts and washers.
    - (a) Torque the bolts to 45 inch-pounds, +5 or -5 inch-pounds.
  - (2) Connect the electrical connector to the roll servo.
  - (3) Install the roll servo bridle cable on the roll servo.
  - (4) Make sure the aileron and bell crank are in the neutral position.
  - (5) Wind the bridle cable around the servo drum approximately 1.25 turns in each direction from the swaged ball (drum ball detent inboard).
  - (6) Make sure the flanges of the bridle cable guard do not touch the bridle cable.
  - (7) Make sure the flanges of the bridle cable guard are on each side of the notches around the outer edge of the mount.
  - (8) Make sure that the primary control cables tension is correct before checking or adjusting bridle cable tension (Refer to Chapter 27, Aileron and Control Column - Maintenance Practices, Rigging Aileron System).
  - (9) Make sure that the roll servo bridle cable tension is 12 pounds, +2 or -2 pounds.
  - (10) If the bridle cable tension is not correct do the steps that follow:
    - (a) Remove panel 232AC (Refer to Chapter 6, Access/Inspection Plates - Description and Operation.)
    - (b) Set the control wheels with the ailerons in neutral position.
    - (c) Put a bar across the control wheels and tape the bar to the control wheels.  
**NOTE: The bar connects the wheels and locks them in the neutral position.**
    - (d) Make sure that the roll servo drum is oriented with the swaged ball on the roll bridle cable at the 12 o'clock position.
    - (e) If either end of the bridle cable is slack, loosen the clamp at that end and move it away from the servo until the cable is no longer slack.
    - (f) Torque the three screws on the right bridle clamp to 25 to 30 inch pounds.
    - (g) Loosen the left bridle clamp just enough to allow it to move.
    - (h) Hold and pull the left bridle cable clamp until the bridle cable tension is 12 pounds, +2 or -2 pounds and torque

the three screws on the left bridle cable clamp to 25 to 30 inch pounds.

- (i) Remove the bars from the control wheels.
- (11) For airplanes 20800416, 20800514, 20800518 thru 20800523, and airplanes 208B2090 and 208B2168 thru 208B2230, put the roll servo fairlead cover in its position on the fairlead guard assembly.
  - (a) Install the screws and the nuts.
- (12) For airplanes 20800524 and On, 208B2231 and On, and airplanes that incorporate CAB10-9, put the roll servo fairlead cover in its position on the fairlead guard assembly.
  - (a) Install the screws.
- (13) Install access panels 232AC and 232DR. Refer to Chapter 6, Access/Inspection Plates - Description and Operation.
- (14) Install the copilot's seat. Refer to Chapter 25, Flight Compartment - Maintenance Practices.
- (15) Connect electrical power to the airplane.
- (16) Load G1000 baseline software/configuration and certification gains to the roll servo. Refer to Chapter 34 Garmin G1000 Integrated Avionics System - Adjustment/Test, G1000 Baseline Software/Configuration Load.
- (17) Do a test of the autopilot as follows:
  - (a) Do the Garmin Autopilot (GFC 700) Functional Check. Refer to, Garmin GFC 700 Automatic Flight Control System (AFCS) - Inspection/Check.
  - (b) Do the Roll Servo Operational Check. Refer to, Garmin GFC 700 Autopilot - Adjustment/Test.
- (18) For more data applicable to servo maintenance procedures refer to section 6 of the G1000 Caravan Line Maintenance Manual and section 3 of the GSA 8X/GSM 85(A) Installation Manual listed in the Introduction, List of Publications.

### 3. Pitch Servo Removal/Installation

- A. Remove Pitch Servo (Refer to Figure 202).
  - (1) Disconnect electrical power from the airplane.
  - (2) Remove the Rear Compartment Wall. Refer to Chapter 25, Rear Compartment Wall - Maintenance Practices.
  - (3) Disconnect the electrical connector from the pitch servo.
  - (4) Release the bridle cable tension and loosen the pitch servo bridle cable at the turnbuckle.
  - (5) Remove the bolts and washers that attach the pitch servo to the bracket assembly.
  - (6) Remove the pitch servo from the airplane.
- B. Install the Pitch Servo (Refer to Figure 202).
  - (1) Put the pitch servo in position on the bracket assembly and attach with the bolts and washers.
    - (a) Torque the bolts to 45 inch-pounds, +5 or -5 inch-pounds.
  - (2) Connect the electrical connector to the pitch servo.
  - (3) Install the pitch servo bridle cable on the pitch servo actuator.
  - (4) Make sure the elevator and bell crank are in the neutral position.
  - (5) Wind the bridle cable around the servo drum approximately 1.25 turns in each direction from the swaged ball (drum ball detent inboard).
  - (6) Make sure the flanges of the bridle cable guard do not touch the bridle cable.
  - (7) Make sure the flanges of the bridle cable guard are on each side of the notches around the outer edge of the mount.
  - (8) Use the turnbuckle to adjust the pitch servo cable tension to 20 pounds, +5 or -5 pounds.
  - (9) Install the Rear Compartment Wall. Refer to Chapter 25, Rear Compartment Wall - Maintenance Practices.
  - (10) Load G1000 baseline software/configuration and certification gains to the pitch servo. Refer to Chapter 34 Garmin G1000 Integrated Avionics System - Adjustment/Test, G1000 Baseline Software/Configuration Load.
  - (11) Do a test of the autopilot as follows:
    - (a) Do the Garmin Autopilot (GFC 700) Functional Check. Refer to, Garmin GFC 700 Automatic Flight Control System (AFCS) - Inspection/Check.
    - (b) Do the Roll Servo Operational Check. Refer to, Garmin GFC 700 Autopilot - Adjustment/Test.

#### 4. Yaw Servo Removal/Installation

- A. Remove Yaw Servo (Refer to Figure 203).
- (1) Disconnect electrical power from the airplane.
  - (2) Remove the Rear Compartment Wall. Refer to Chapter 25, Rear Compartment Wall - Maintenance Practices.
  - (3) Disconnect the electrical connector from the yaw servo.
  - (4) Release the bridle cable tension and loosen the yaw servo bridle cable at the turnbuckle.
  - (5) Remove the bolts and washers that attach the yaw servo to the bracket.
  - (6) Remove the yaw servo from the airplane.
- B. Install the Yaw Servo (Refer to Figure 203).
- (1) Put the yaw servo in position on the bracket and attach with the bolts and washers.
    - (a) Torque the bolts to 45 inch-pounds, +5 or -5 inch-pounds.
  - (2) Connect the electrical connector to the yaw servo.
  - (3) Install the yaw servo bridle cable on the yaw servo actuator.
  - (4) Make sure the rudder and bell crank are in the neutral position.
  - (5) Wind the bridle cable around the servo drum approximately 1.25 turns in each direction from the swaged ball (drum ball detent inboard).
  - (6) Make sure the flanges of the bridle cable guard do not touch the bridle cable.
  - (7) Make sure the flanges of the bridle cable guard are on each side of the notches around the outer edge of the mount.
  - (8) Make sure that the primary control cables tension is correct before checking or adjusting bridle cable tension (Refer to Chapter 27, Rudder - Maintenance Practices, Rudder System Rigging).
  - (9) Make sure that the yaw servo bridle cable tension is 20 pounds, +2 or -2 pounds.
  - (10) If the bridle cable tension is not correct do the steps that follow:
    - (a) Make sure that the rudder is in the neutral position.
    - (b) Make sure that the swagged ball on the yaw bridle cable is positioned on the forward side of the yaw servo drum, centered between the two forward yaw servo attachment bolts.
    - (c) If either end of the bridle cable is slack, loosen the clamp at that end and move it away from the servo until the cable is no longer slack.
    - (d) Torque the three screws on each bridle cable clamp to 25 to 30 inch pounds.
    - (e) Remove the turnbuckle clips and use the turnbuckle to set the yaw bridle cable tension to 20 pounds +5 or -5 pounds.
    - (f) Install the turnbuckle clips on the turnbuckle.
  - (11) Install the Rear Compartment Wall. Refer to Chapter 25, Rear Compartment Wall - Maintenance Practices.
  - (12) Load G1000 baseline software/configuration and certification gains to the yaw servo. Refer to Chapter 34 Garmin G1000 Integrated Avionics System - Adjustment/Test, G1000 Baseline Software/Configuration Load.
  - (13) Do a test of the autopilot as follows:
    - (a) Do the Garmin Autopilot (GFC 700) Functional Check. Refer to, Garmin GFC 700 Automatic Flight Control System (AFCS) - Inspection/Check.
    - (b) Do the Roll Servo Operational Check. Refer to, Garmin GFC 700 Autopilot - Adjustment/Test.

#### 5. Pitch Trim Servo Removal/Installation

- A. Remove the Pitch Trim Servo (Refer to Figure 204).
- (1) Disconnect electrical power from the airplane.
  - (2) Get access to the pitch trim servo. Refer to Chapter 27, Electric Elevator Trim - Removal/Installation.  
**NOTE: The Electric Elevator Trim - Removal/Installation section gives the method necessary to remove and install the electric elevator trim motor that is installed on some models. This same method is valid to remove and install the pitch trim servo.**
  - (3) Disconnect the electrical connector from the pitch trim servo.

- (4) Remove the pitch trim servo from the airplane.
  - (5) Do an inspection of the pitch trim servo. Refer to section 6 of the G1000 Caravan Line Maintenance Manual and section 3 of the GSA 8X/GSM 85(A) Installation Manual listed in the Introduction, List of Publications.
- B. Install the Pitch Trim Servo (Refer to Figure 204).

- (1) Install the pitch trim servo in the airplane. Refer to Chapter 27, Electric Elevator Trim - Removal/Installation.
  - (a) Torque the bolts to 45 inch-pounds, +5 or -5 inch-pounds.

**NOTE:** The Electric Elevator Trim - Removal/Installation section gives the method necessary to remove and install the electric elevator trim motor that is installed on some models. This same method is valid to remove and install the pitch trim servo.

- (2) Connect the electrical connector to the pitch trim servo.
- (3) Close access to the pitch trim servo. Refer to Chapter 27, Electric Elevator Trim - Removal/Installation.
- (4) Load G1000 baseline software/configuration and certification gains to the pitch trim servo. Refer to Chapter 34 Garmin G1000 Integrated Avionics System - Adjustment/Test, G1000 Baseline Software/Configuration Load.
- (5) Do a test of the autopilot as follows:
  - (a) Do the Garmin Autopilot (GFC 700) Functional Check. Refer to, Garmin GFC 700 Automatic Flight Control System (AFCS) - Inspection/Check.
  - (b) Do the Manual Electric Trim (MET) Switch Operational Check. Refer to, Garmin GFC 700 Autopilot - Adjustment/Test.
  - (c) Do the Pitch Trim Rigging Inspection.

## 6. Pitch Trim Rigging Inspection

- A. Do a check of the pitch trim rigging.
- (1) Attach an inclinometer to the trim tab.
  - (2) Put the trim tab in the 0 degree position.
  - (3) Manually operate the trim tab to the up and down limits.
    - (a) Record the limits of travel.
  - (4) Have an observer at the right-hand access opening of the tailcone.
  - (5) Put the electrical trim to the full nose-up position until the observer sees the clutch slip.
  - (6) Turn the manual trim wheel nose-up (test load condition) 1/4 turn more while the clutch slips.
  - (7) Make sure the swaged ball on the bridle cable assembly does not turn aft of the tangent point.
  - (8) Release the trim wheel and disengage the autopilot.
  - (9) Manually operate the trim to the full nose-up position.
  - (10) Do a check of the trim tab position with an inclinometer.

**NOTE:** Trim tab position that is greater than the limits of travel values recorded is an indication that the stop blocks slipped.

- (11) If the stop blocks slip, do the steps that follow.
  - (a) Do the trim system rigging again.
  - (b) Make sure the stop block bolts torque is correct.
  - (c) Do a check of the pitch trim rigging again.
- (12) If necessary, make adjustments to the swaged ball position.
  - (a) Put the bridle cable assembly chain in the applicable position on the gear teeth of the actuator sprocket.

**NOTE:** One chain link adjustment is related to approximately 17 degrees of travel on the capstan.
  - (b) Apply the applicable tension to the bridle cable and do a check of the pitch trim rigging again.
- (13) Do the procedure again for the full nose-down trim condition.
- (14) For more data applicable to servo maintenance procedures refer to section 6 of the G1000 Caravan Line Maintenance Manual and section 3 of the GSA 8X/GSM 85(A) Installation Manual listed in the Introduction, List of Publications.

## 7. Servo Capstan Clutch Adjustment

- A. Adjust the servo capstan clutch in accordance with the G1000 Caravan Line Maintenance Manual and servo mount installation manual. Refer to Introduction, List of Publications for the manufacturer's installation manual.

**NOTE:** If the servo mount that was removed was a GSM 86 the servo capstan clutch torque is set when it is manufactured and cannot be adjusted. If the GSM 86 servo mount is not serviceable it must be replaced or sent to Garmin for servicing.

Figure 201 : Sheet 1 : Autopilot Roll Servo Installation

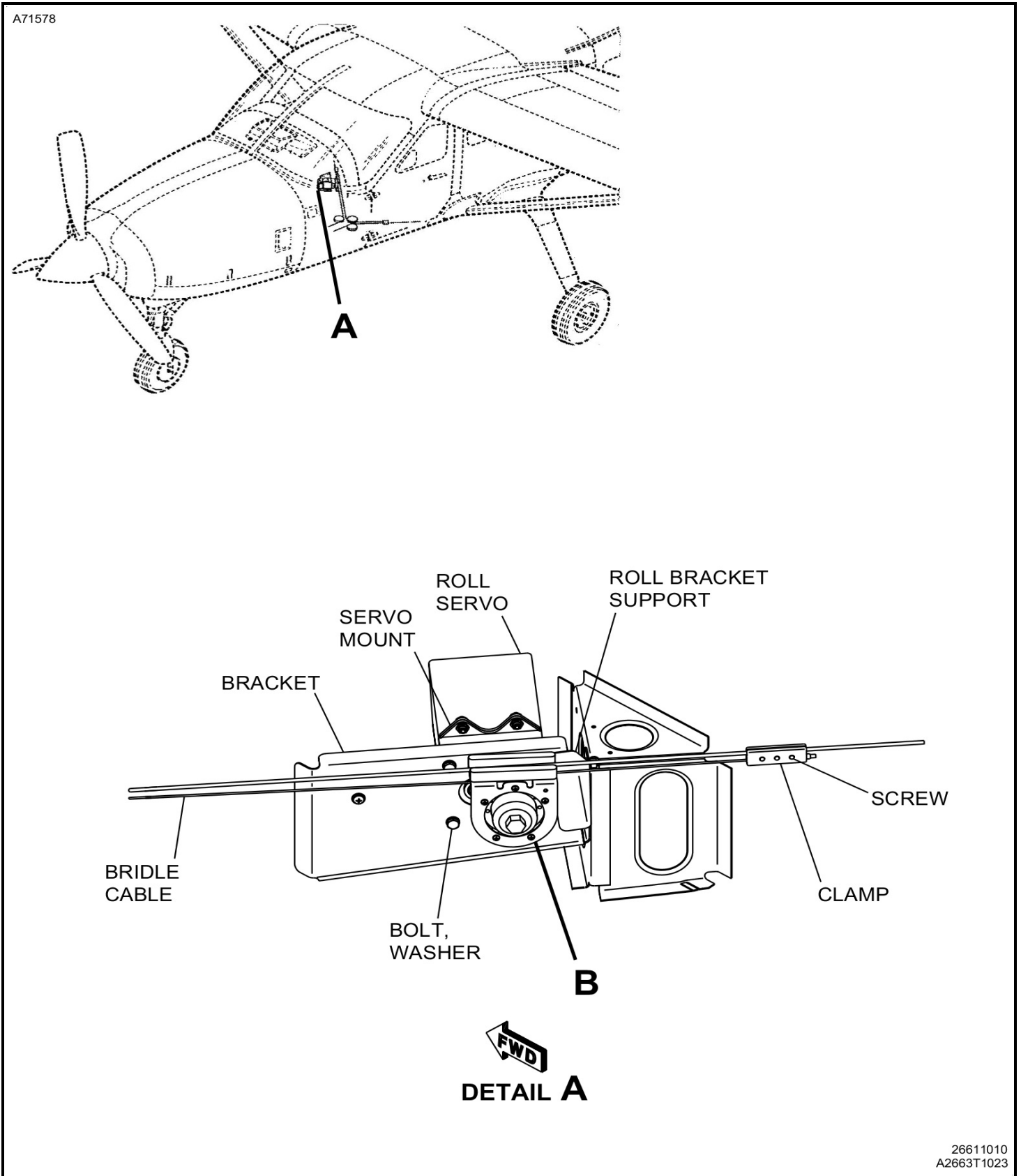
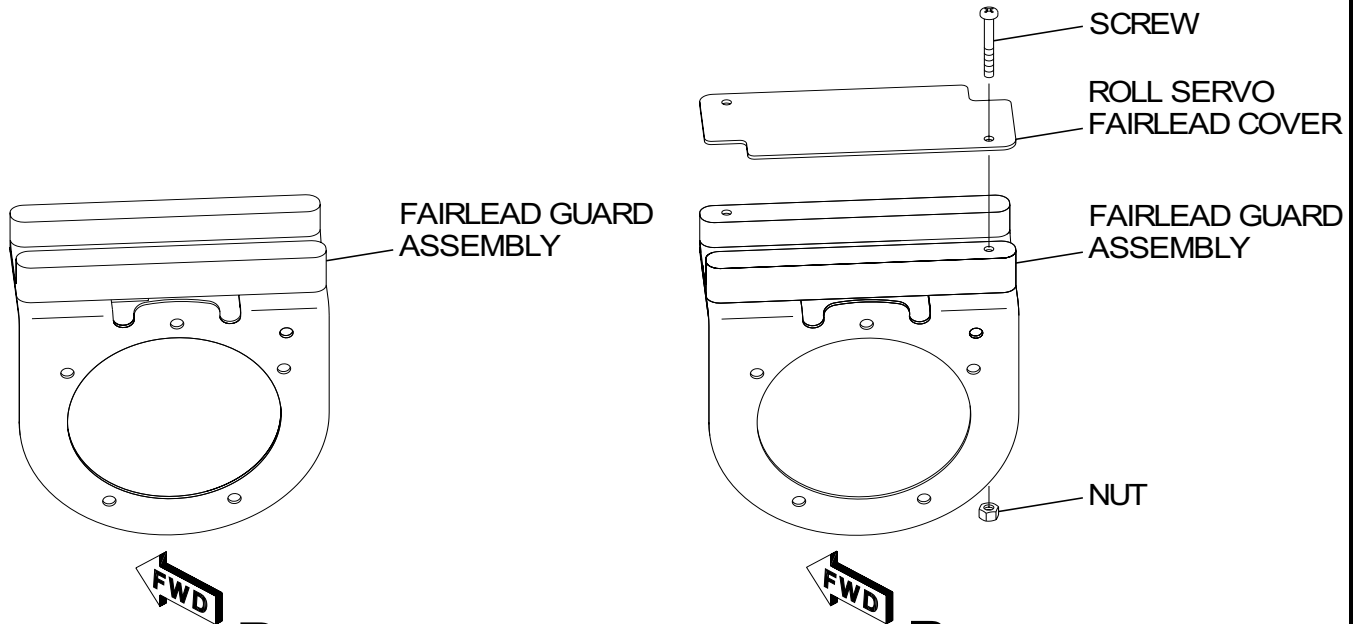

Figure 201 : Sheet 2 : Autopilot Roll Servo Installation

A83788



**DETAIL B**

AIRPLANES 20800500 THRU 20800513,  
 20800515 THRU 20800517, AND  
 AIRPLANES 208B2000 THRU 208B2089,  
 208B2091 THRU 208B2167

**DETAIL B**

AIRPLANES 20800416, 20800514,  
 20800518 THRU 20800523, AND  
 AIRPLANES 208B2090 AND  
 208B2168 THRU 208B2230

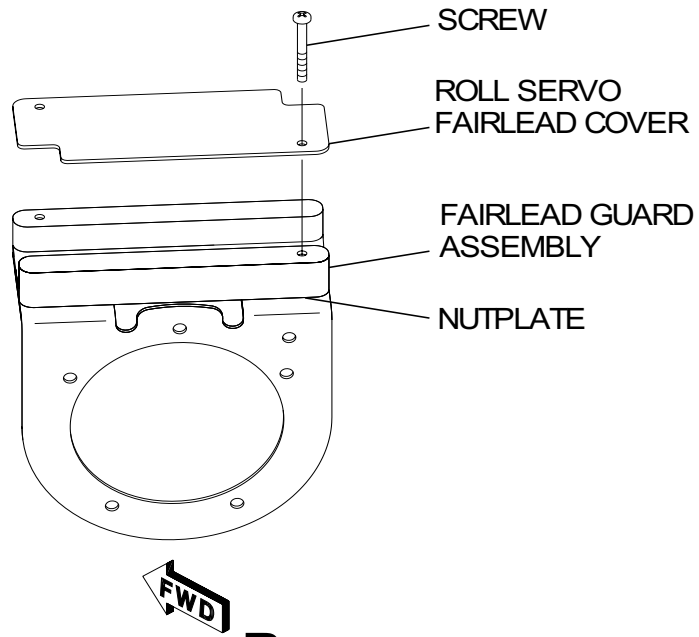

**DETAIL B**

AIRPLANES 20800524 AND ON,  
 AIRPLANES 208B2231 AND ON, AND  
 AIRPLANES THAT INCORPORATE CAB10-9

B2663T1023  
 B2615T1045  
 B2615T1045

Figure 202 : Sheet 1 : Autopilot Pitch Servo Installation

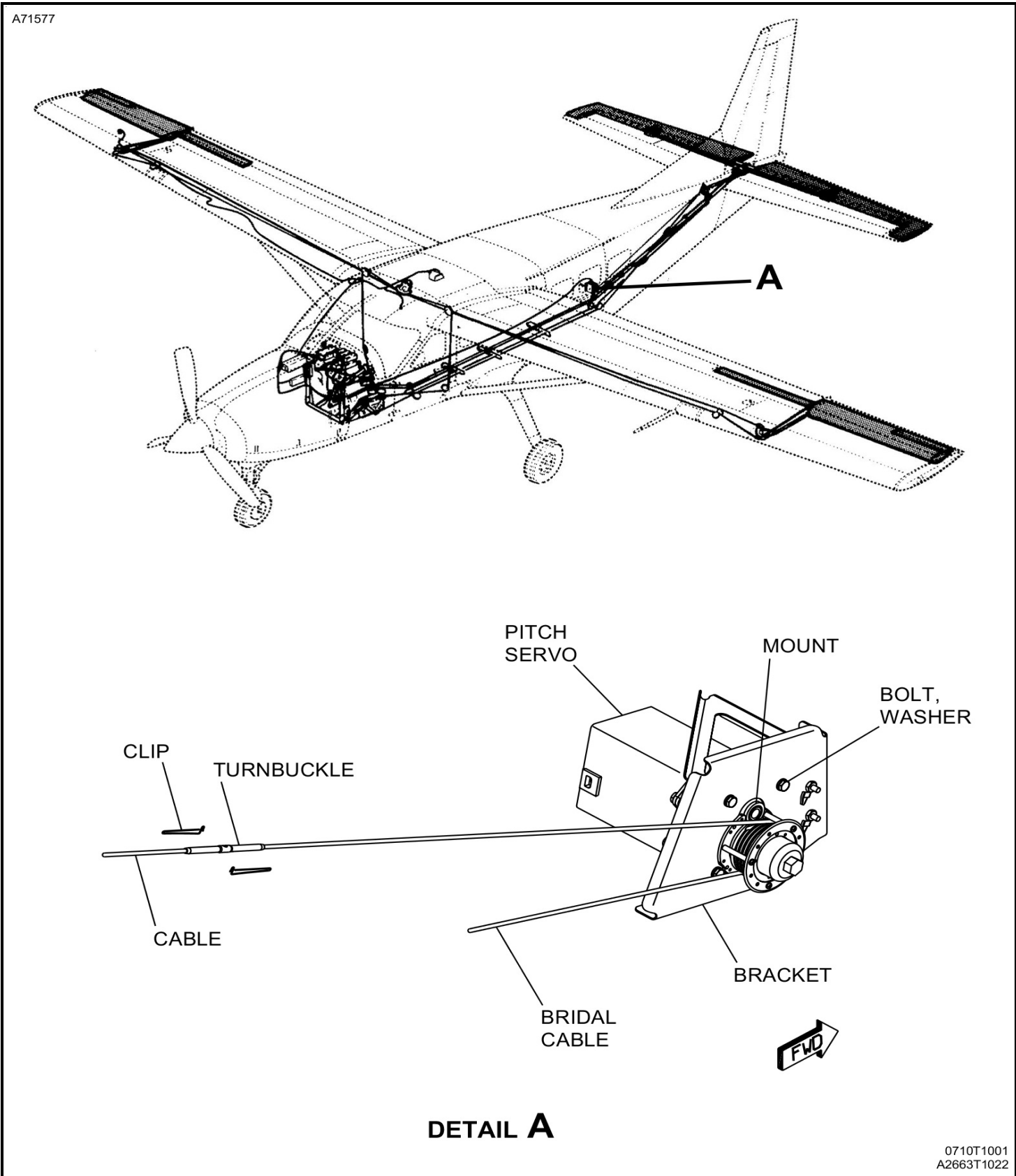



Figure 203 : Sheet 1 : Autopilot Yaw Servo Installation

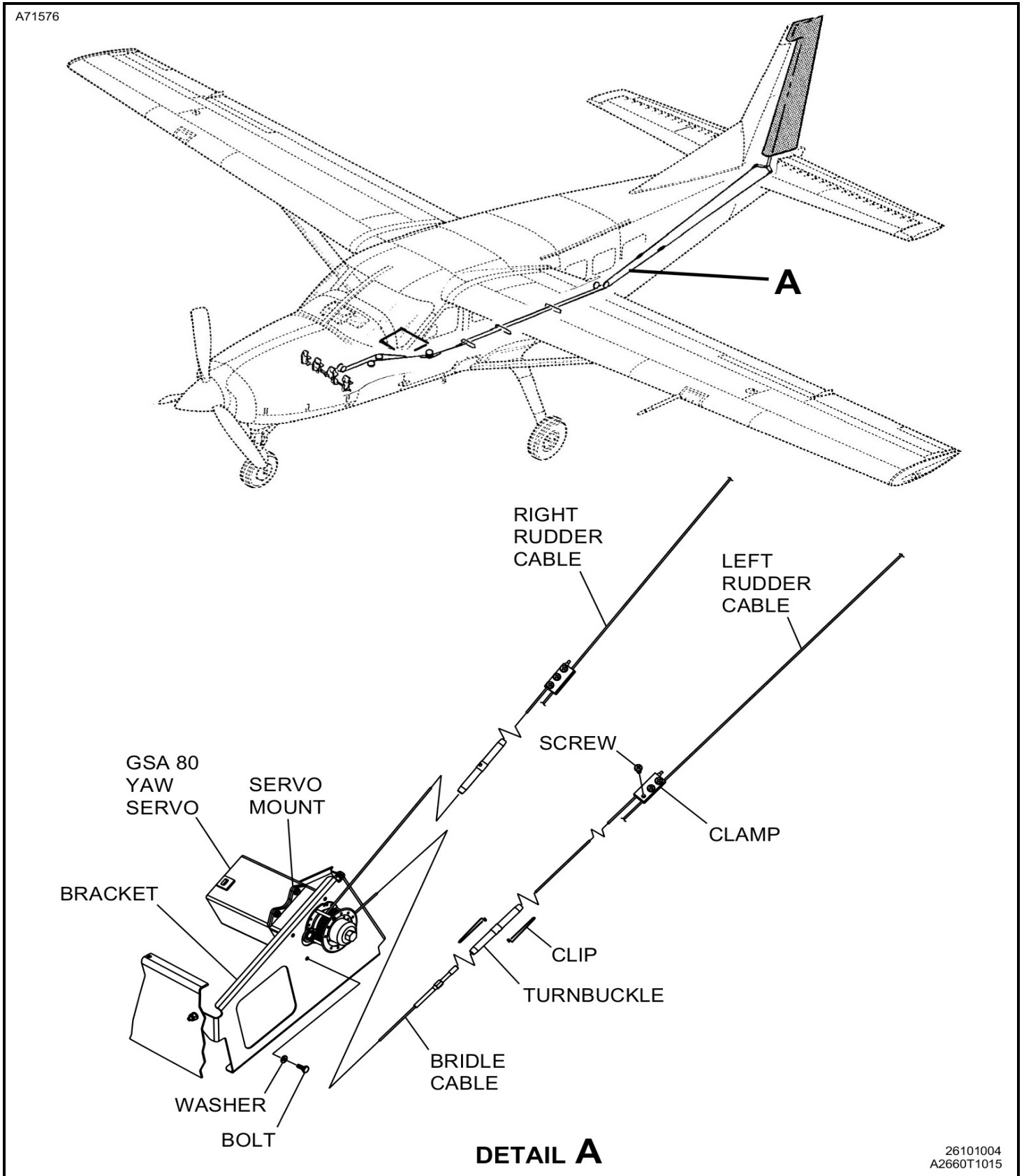

Figure 204 : Sheet 1 : Autopilot Pitch Trim Servo Installation

